

Furniture lift Junior 24e



Technical Data

| | |
|--------------------------------|-----------------------------|
| Model | HD 24/0-7 braked |
| Payload [kg] | 250 |
| Permissible total weight [kg] | 1,400 |
| Permissible axle load [kg] | 1,300 |
| Driving licence class | B/B96/BE |
| Maximum carriage speed [m/min] | 48 |
| Total length [mm] | 5,120 |
| Total width [mm] | 1,299 |
| Package length [mm] | 4,000 |
| Track width [mm] | 540 |
| Extendable from - to [m] | 4.1 - 23.7 |
| Drive | E-motor / battery |

Sustainable working is now easier than ever. The Junior 24e electric lift with rechargeable battery charges at any Schuko socket and, thanks to the powerful energy storage unit, also works in places without a power connection. Equipped with an electric motor and state-of-the-art lithium-ion battery technology, the inclined lift transports loads up to 250 kg to maximum heights of 24 m with minimum noise and minimum emissions making it extremely environmentally friendly. Even during the charging process, the lift can be used as normal.

In addition to the environmentally-friendly drive concept, the Junior 24e impresses by its newly developed chassis for space-saving, quick assembly within a few minutes. Thanks to its compact and well thought-out design, the inclined lift finds a place for setup even in extremely tight spaces and can be towed by all standard cars due to its low total weight.

Dimensions

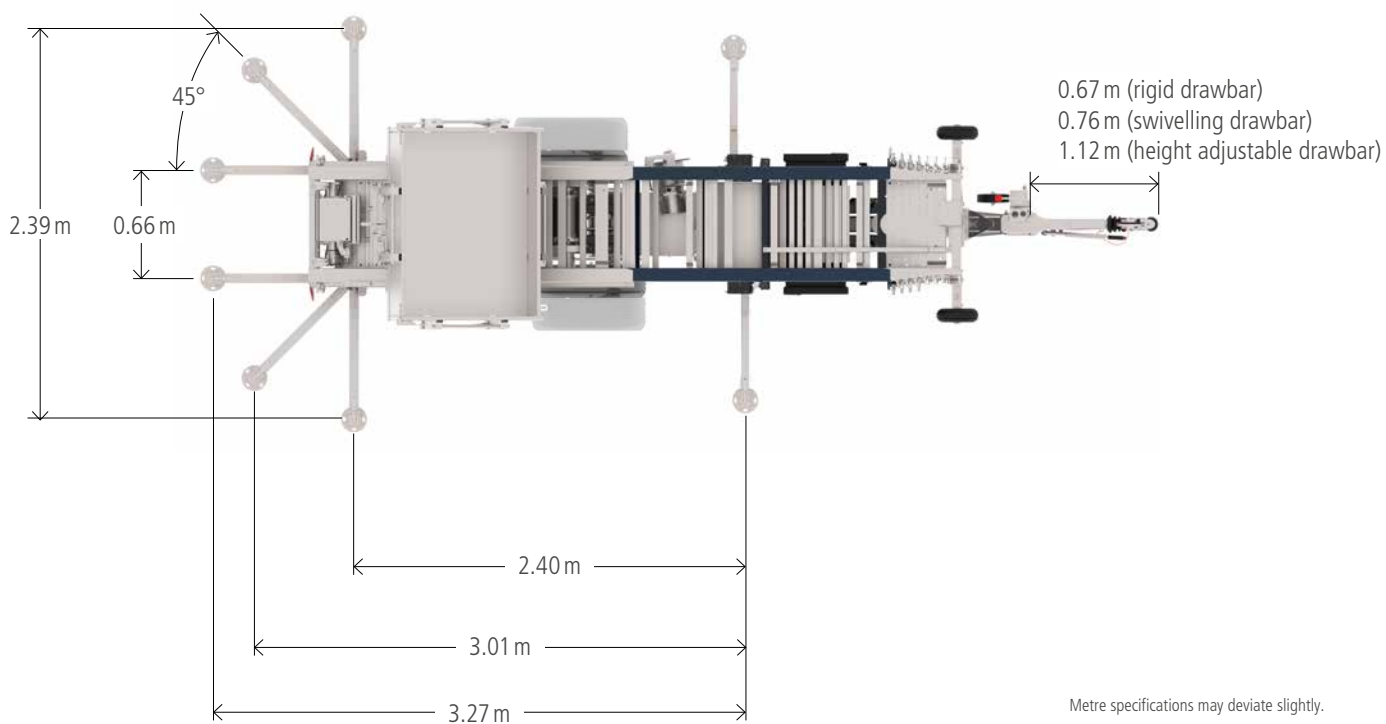
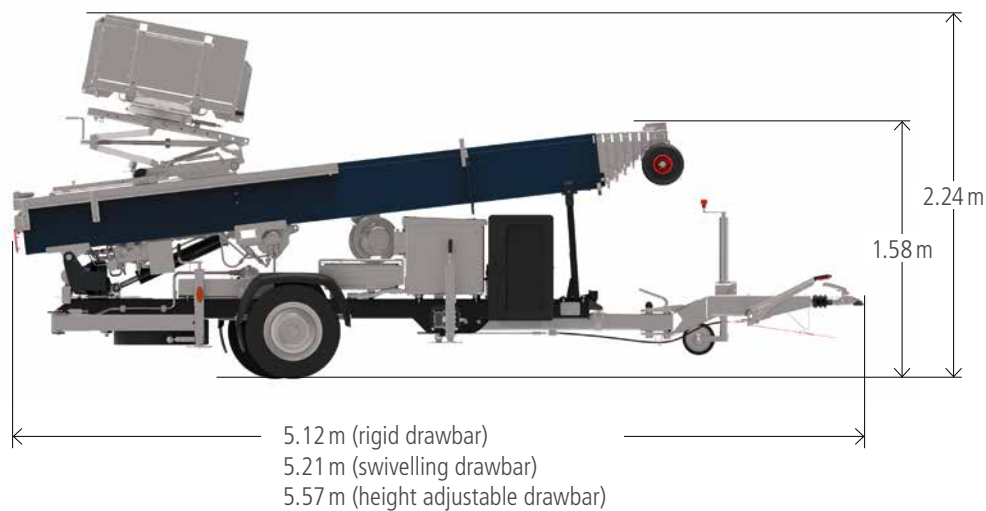

Metre specifications may deviate slightly.